

## HF 6012-24-3,3-DTP

DC hydraulic power unit for bogie lift axle



This hydraulic power pack is designed for electro-hydraulic rear axis bogie lifts.

### Replacement:

It can replace the units of the main manufacturers like Scania, Volvo and Sisu Trucks.

### Advantages:

- full 1 year guarantee
- fast fitting = reduced costs
- easy to fit (4 bolts)
- adaptable to existing hydraulic system
- reliable

**This power pack is designed as replacement for Scania, Volvo and Sisu Trucks.**

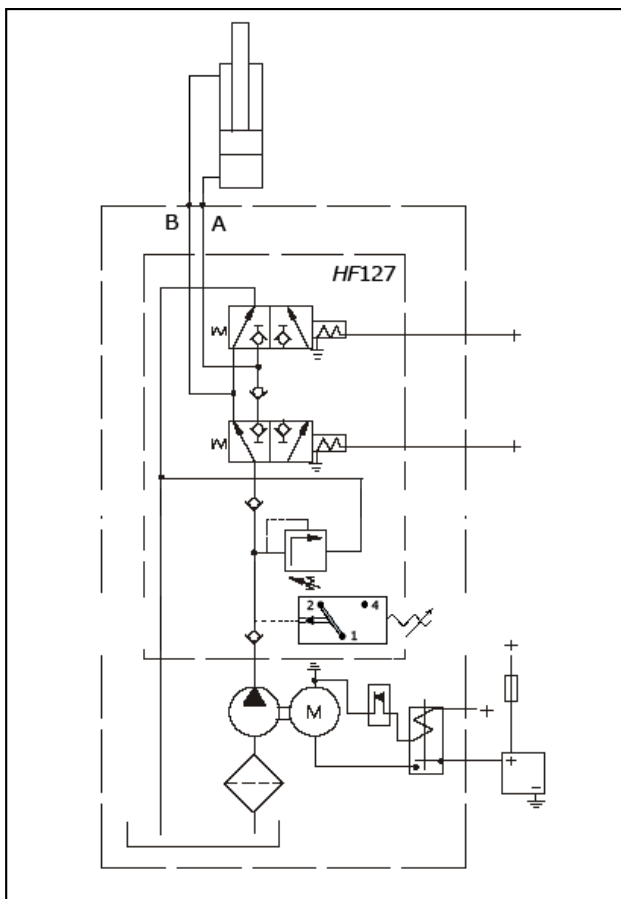

HF power pack type "6012-24"

hydraulic power unit for double acting functions.

incl. pressure switch

for bogie lifts

Pressure switch:

Power units "TP" are with adjustable pressure switch HF3040.