

12V c.c. - d.c.

9000-30000452

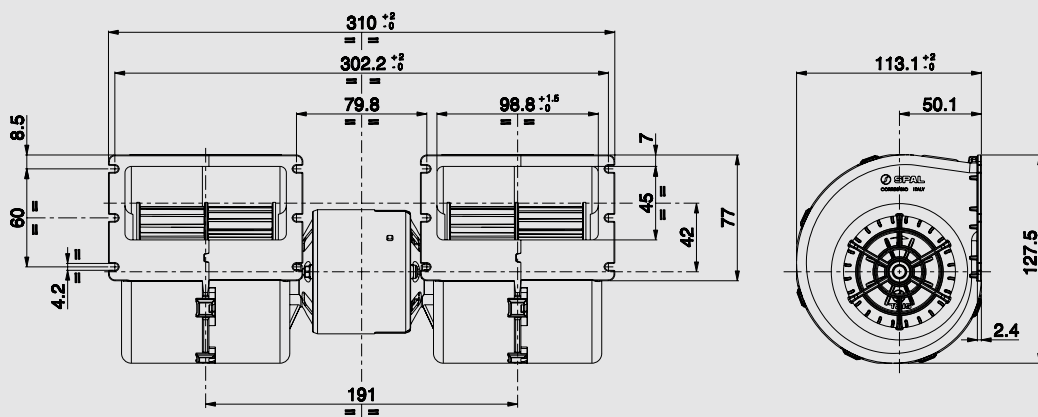

Suggested mounting torque: 3 +1/- 0 Nm with screw M4  
For mounting use wide-head screw or washer to fasten the unit  
Weight 1,7 Kg. approx.

Coppia di serraggio consigliata: 3 +1/- 0 Nm con vite M4  
Per il fissaggio utilizzare viti a testa larga o rondella  
Peso 1,7 Kg. circa

008

PERFORMANCE CHART  
SCHEDE PRESTAZIONI

Static pressure Pressione statica mm H <sub>2</sub> O	Airflow Portata m <sup>3</sup> /h	Current input Corrente assorbita A	Airflow Portata CFM	Static pressure Pressione statica in H <sub>2</sub> O
0	690	15,1	407	0
10	630	13,7	372	0,4
15	580	12,9	342	0,6
20	550	12,2	325	0,8
25	510	11,9	301	1,0
30	470	10,7	277	1,2
35	400	10,0	236	1,4
40	270	8,0	159	1,6
45	130	6,5	77	1,8
50	0	5,6	0	2,0

Test voltage 13 V d.c. - Tensione di prova 13 V c.c.



PRODUCT FEATURES  
CARATTERISTICHE PRODOTTO

Long life  
Lunga durata ✓

Low noise  
Bassa rumorosità ✓

✓ = Standard feature  
Caratteristica standard